

Web Adapter EM02



Serial - V1.6

Web access for embedded systems

A small module makes it possible: the Web Adapter EM02 connects microcomputers, single-chip processors and single-board computers simply with the internet.

The native intelligence of the on-board processor handles all necessary operations and considerably reduces the load on the actual control. At last, a powerful web access utilisation in a microprocessor application is possible, which is also simple to integrate.

Easy to use program examples mean a quick start and guarantee short development periods.

With its slight dimensions of 3.9 x 2.8 x 1.0 cm, weight of 19 grams and 28 pin Dip-type module-casing there is ample room for the adapter. The chip connects to a 5V DC energy source and its interface is compatible with 3V / 5V.

The Web Adapter is available in two models: with a serial interface (1.200 to 38.400 Bd ASYNC) 3V / 5V gage (EM02) or with an 8-bit parallel interface (EM04).

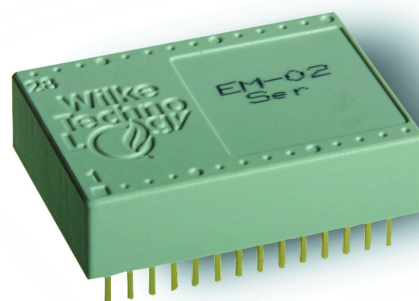

Application Areas:

- ◆ Connection to Internet via MODEM
- ◆ Connection to Internet via GPRS-MODEM
- ◆ Remote control of devices
- ◆ Car and container tracking
- ◆ Facility management
- ◆ Embedded Web Server or Client

Protocols:

The EM02 Web Adapter handles already locally these communication levels:

- ◆ PPP
- ◆ IP
- ◆ TCP
- ◆ UDP (since module version V1.6)
- ◆ DHCP
- ◆ DNS
- ◆ SNTP (since module version V1.6)

Contents

◆ Pin-Definitions	Page 2
◆ Case Dimension	Page 2
◆ Connection to Tiger	Page 3
◆ BAUD Rate select	Page 4
◆ Using a MODEM with V.24 Interface	Page 5
◆ Specifications	Page 6
◆ Revision table	Page 7

Web Adapter EM02

Serial - V1.6

Pin-Definition

Name	Pin	Type	Description
VCC	28	PWR	+5V dc Supply
GND	14	PWR	0V Supply
/Reset	13	In	Reset Input low active
TxD_T	26	Out	Serial Transmit Signal (connect to Tiger)
RxD_T	25	In	Serial Receive Signal (connect to Tiger)
RTS_T	10	Out	Handshake (connect to Tiger)
CTS_T	9	In	Handshake (connect to Tiger)
BAUD0	6	In	BAUD Rate select Bit0 (for communication with Tiger)
BAUD1	7	In	BAUD Rate select Bit1 (for communication with Tiger)
BAUD2	8	In	BAUD Rate select Bit2 (for communication with Tiger)
TxD_M	21	Out	Serial Transmit Signal (connect to MODEM)
RxD_M	22	In	Serial Receive Signal (connect to MODEM)
RTS_M	23	Out	Request To Send (connect to MODEM)
CTS_M	24	In	Clear To Send (connect to MODEM)
/PG_EN	1	In	reserved for future updates
PG_CLK	2	In	reserved for future updates
PG_DIN	3	In	reserved for future updates
PG_DOUT	4	Out	reserved for future updates

All signals except power supply are 5V tolerant LVTTTL signals (0V....3.3V)
The other pins are reserved for future functions. Do not connect the reserved pins.

Case Dimension

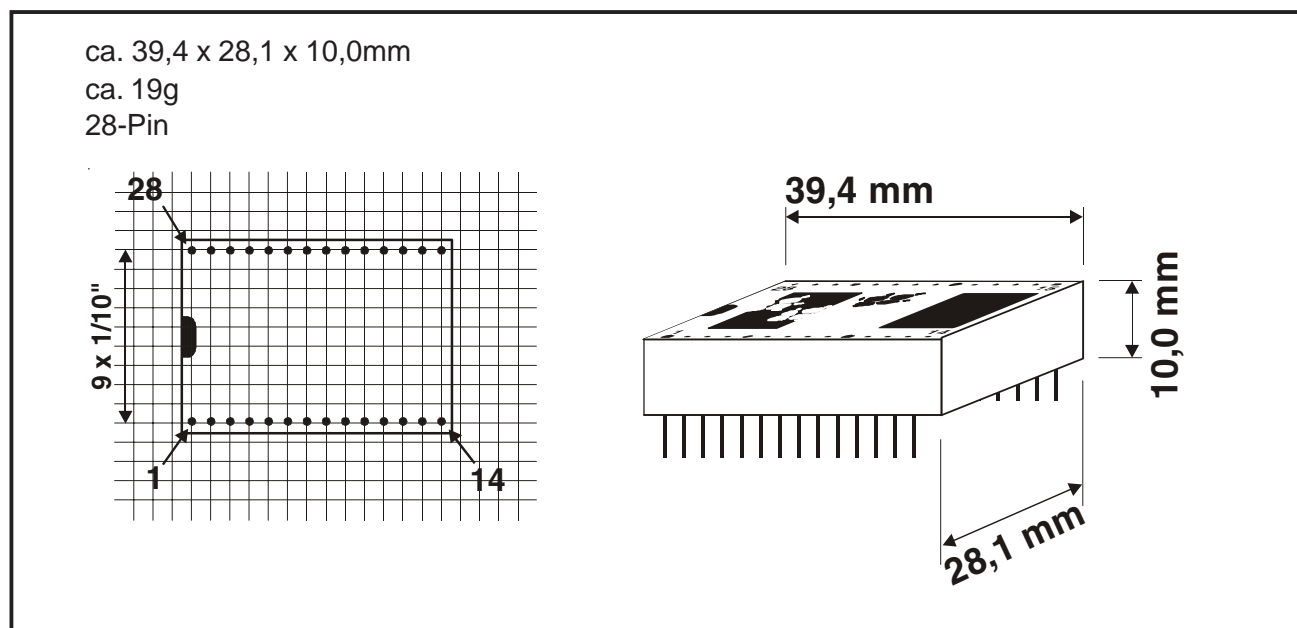

Technical Documentation

Web Adapter EM02



Serial - V1.6

Connection to Tiger

Connect the RxD_T signal of the Web Adapter EM02 to the TxD0 pin of your BASIC-Tiger Computer, the TxD_T signal to the RxD0 pin, the RTS_T signal to the CTS0 pin and the CTS_T signal to the RTS0 pin. The RESET pins should be tied together with a diode as shown in the figure below.

Only use 5V / 3V signal levels for serial interfacing.
Do not use RS232 voltage levels as used by AXN or AXI Tigers.

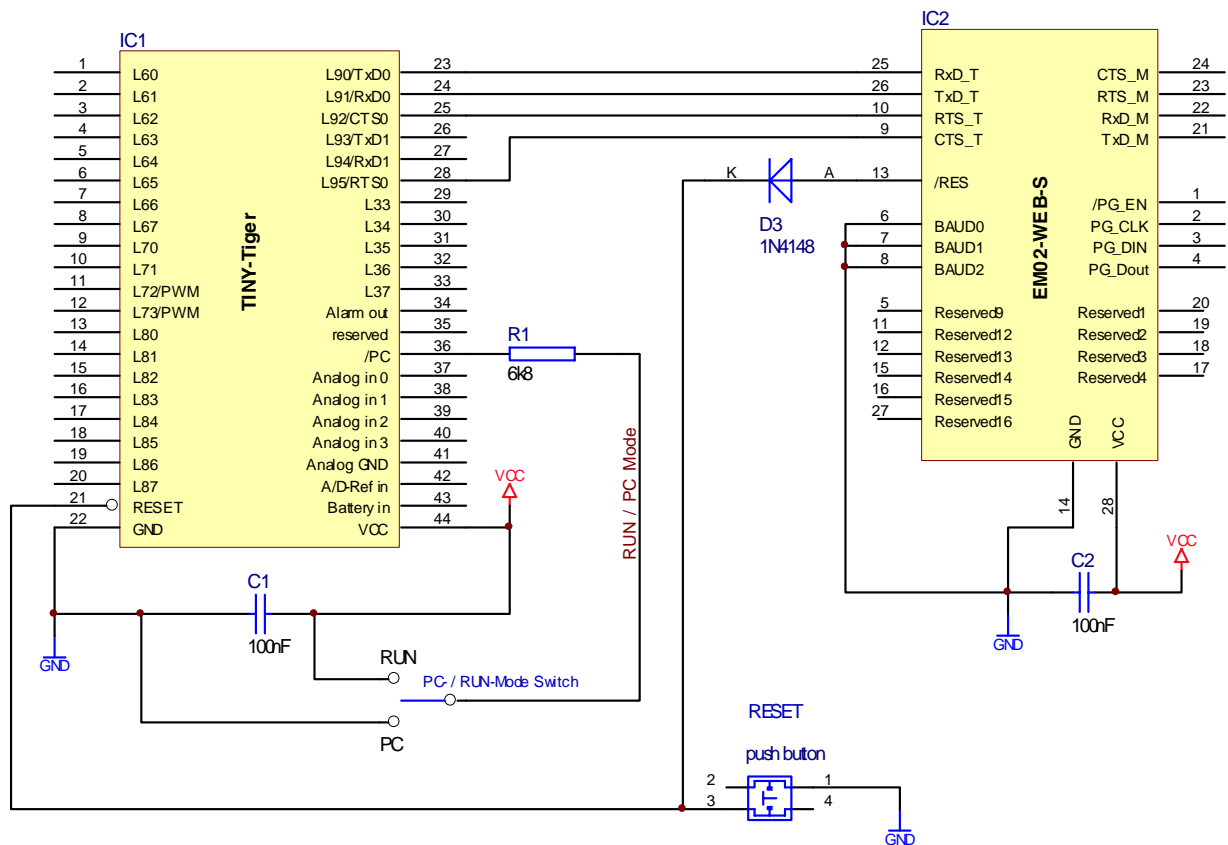

Technical Documentation

Web Adapter EM02



Serial - V1.6

BAUD Rate select

To communicate with a BASIC-TIGER you must select the same BAUD-Rate as you selected in your BASIC program. After Power-ON or RESET the Web Adapter EM02 reads the signals BAUD0, BAUD1 and BAUD2. Connect them to GND to get the default BAUD rate 19200 Bits/s. You can select other BAUD rates connecting at least one to logic high level:

BAUD2	BAUD1	BAUD0	BAUD-Rate
low	low	low	19.200 (default)
low	low	high	1.200
low	high	low	2.400
low	high	high	4.800
high	low	low	9.600
high	low	high	19.200
high	high	low	38.400

The interface parameters are: 8 Data Bit, No Parity, 1 Stop Bit.

To select the BAUD-Rate with DIP switches you may use following circuit diagram

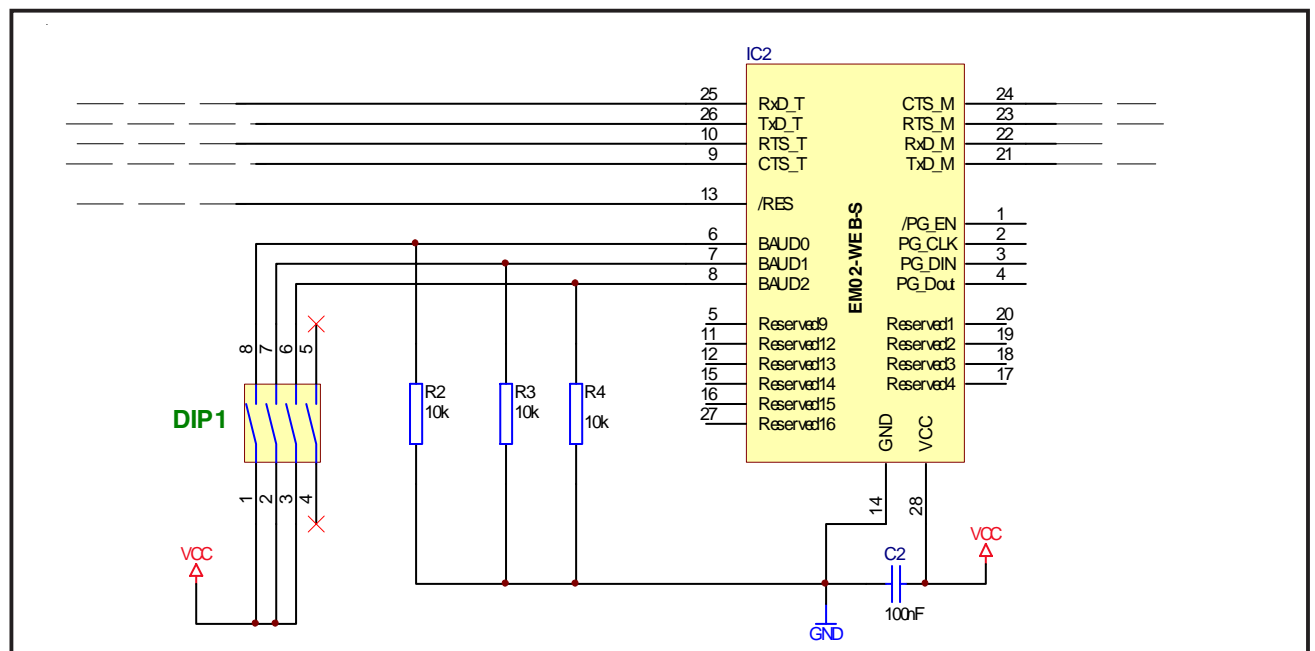

Technical Documentation

Web Adapter EM02

Serial - V1.6

Using a MODEM with V.24 Interface

To use a MODEM with V.24 Interface you must connect a RS232 driver / receiver to the Web Adapter EM02 e.g. MAX232 from MAXIM.

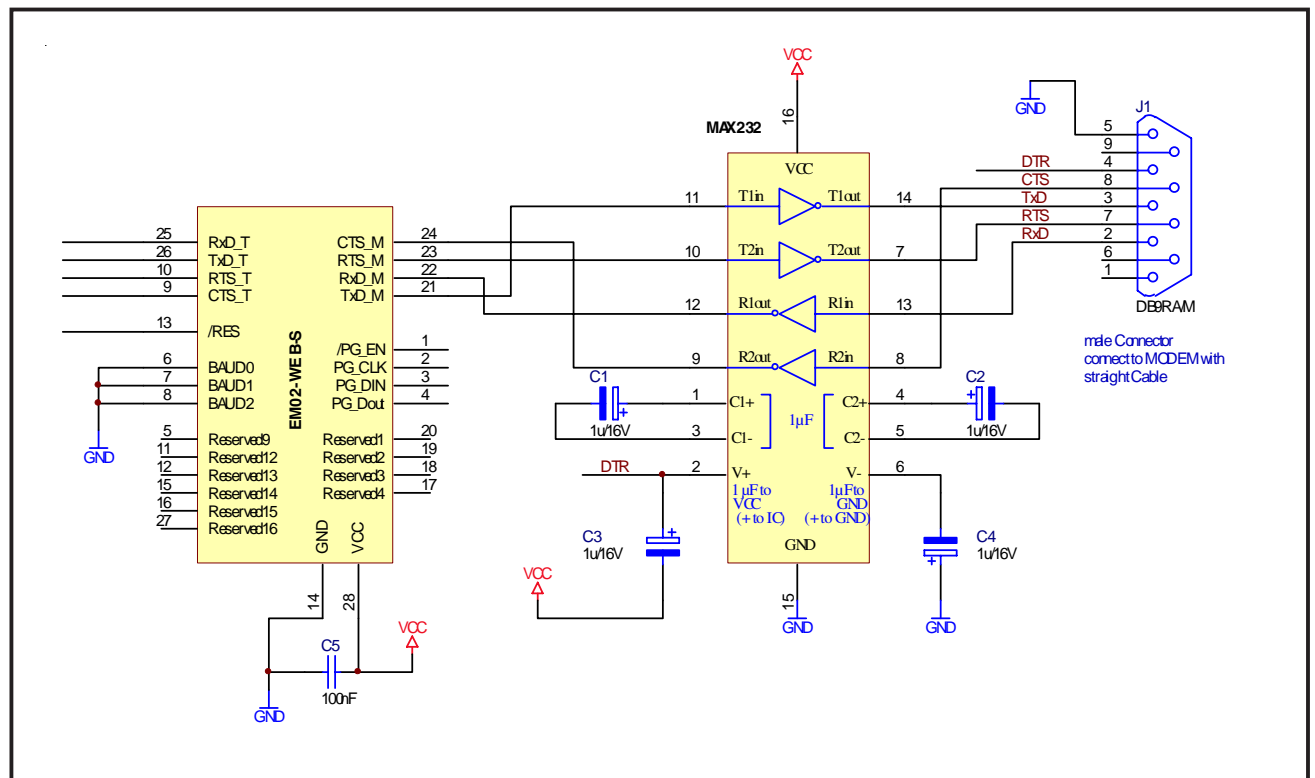

Technical Documentation

Web Adapter EM02



Serial - V1.6

Specifications

Absolute maximum ratings (beyond which permanent damage may occur)

supply voltage VCC	5.5V
input voltage on any input pin	5.5V
maximum current per output pin	100mA
operating temperature	min. 0°C max. 50°C
Do not connect the reserved pins	

DC Specifications

Parameter	Conditions	Value
supply current		170mA
input low voltage input low voltage (/RESET)		1.0V max. 0.9V max.
input high voltage input high voltage (/RESET)		1.8V...5.5V 2.25V...5.5V
output high current output low current	Voh=2.4V Vol=0.4V	11mA (min.) 9mA
input leakage current input leakage current	logic value does change state logic value does not change	-80µA...80µA -1µA...1µA
input leakage current for /RESET		-60µA...335µA

Web Adapter EM02



Serial - V1.6

Revision Table

Dokument	Adapter Version	Changes
V001	1.3	-
V002	1.3	Introduction added
V003	1.3	DC-Spcifications Supply Current added
V004	1.4	adapter revision: handshake signals added revision table added
V005	1.4	default BAUD rate changed
V006	1.4	default BAUD rate corrected
V007	1.5	adapter revision: temperature performance improved Pin-Definition corrected, module name changed to EM02-WEB-S
V008	1.5	some values in DC-Specification added
V009	1.6	DTR signal in example schematic correctet adapter revision: protokol UDP and SNTP added.
V010	1.6	some changes in the documentation layout done